

Piezo Tip/Tilt Systems

Design – Performance – Tuning



Contents

1	Overview	3
2	Design and Functional Principle	3
3	Condition on Delivery and Quality	4
4	Handling the Mirror	5
5	Controlling Tip/Tilt Systems	5
5.1	<i>Choosing the Matching Control Electronics</i>	5
5.2	<i>PIMikroMove: Easy Configuration and Startup</i>	6
6	During Operation	6
6.1	<i>Hysteresis</i>	6
6.2	<i>Resonant Frequencies</i>	7
6.3	<i>Step Response and Settling Time</i>	7
6.4	<i>Heat Generation During Continuous Operation</i>	8
6.5	<i>Position Drift</i>	9
6.6	<i>Lifetime</i>	9
7	OEM Engineering and Solutions	10
8	FEM Optimization	10
9	Simulation of the Overall System	10
10	Author	10
	About PI	11

1 Overview

Piezo tip/tilt systems from Physik Instrumente (PI) are versatile positioning systems – they are ideal for dynamic operation in applications such as scanning, tracking, for suppressing drift oscillation or dynamic image stabilizing. Piezo tip/tilt systems and scanners offer greater acceleration and dynamic bandwidth than similar actuators such as for example, voice coil or galvanometer scanners. Piezo tip/tilt systems developed by PI are also found in applications for quasistatic positioning of optics with high demands on "pointing stability".

All piezo tip/tilt systems manufactured by PI are equipped with flexure guides for friction-free motion and therefore provide excellent guiding accuracy. Resolutions into the nanoradian range are possible and at the same time, high angle stability. Optical deflection angles of up to 70 mrad can be achieved with very short settling time (milliseconds to microseconds).

2 Design and Functional Principle



Note: Despite their massive and robust appearance, PI piezo tip/tilt mirrors are sensitive precision systems. The effects of forces and torques on the tip/tilt platform are particularly critical during assembly. This needs to be minimized or avoided at all times. PI provides the corresponding instructions for assembly and adjustment.

PI piezo tip/tilt systems are offered in single- and multi-axis versions. In addition, differential piezo tip/tilt systems are equipped with two piezo actuators per axis.

The motion platform for systems with **one piezo actuator** such as for Fig. 1 (left-hand graphic), is guided by a flexure. The flexure forms the center of rotation (pivot point) and at the same time, preloads the piezo actuator. Simple design, low costs, and small installation space are among the advantages of this version. A differential piezo drive is recommended for applications that require high angular stability over a wide temperature range.

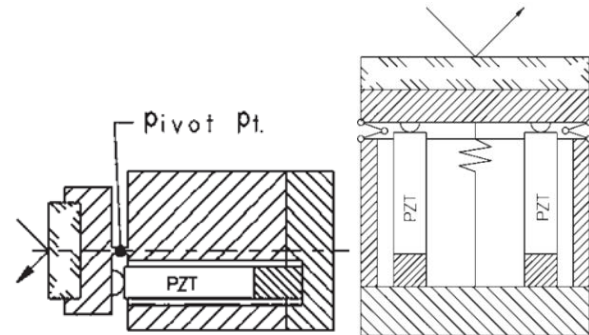

Fig. 1 Schematic diagram of a piezo tip/tilt mirror with a piezo actuator (left) and differential drive (right). The pivot point of the differential drive piezo tip/tilt system can be obtained from the technical drawing (image: PI)

The design of the piezo tip/tilt systems with **differential drive** is based on **two** piezo actuators (for this, see Fig. 1, right-hand graphic) that drives the platform in push/pull mode. For this purpose, both actuators are operated electrically in a bridge circuit supplied with a fixed voltage and controlled by a variable voltage. The differential design allows the highest angular stability over a wide temperature range because the changes in temperature only affect one linear offset shift of the platform. The use of strain gauge sensors makes both high linearity and excellent repeatability possible.

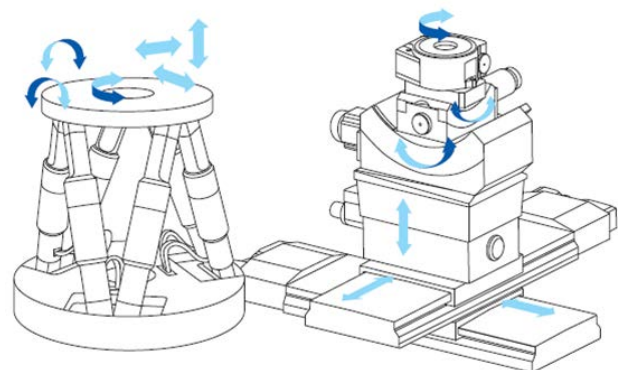

Fig. 2 Motion directions of parallel kinematics (left) and a comparable serial setup (right) (image: PI)

Multi-axis piezo tip/tilt systems are designed as parallel-kinematic systems (Fig. 2). This design has great advantages compared to serial systems. The motion platform is displaced only around **one** fixed center of rotation.

Therefore, the higher system resonant frequency results in higher dynamics. In addition, parallel-kinematic systems achieve much better linearity than serial systems. Serial systems work by switching two single-axis system successively – e.g., galvanometer scanners.

PI offers standard designs with two and three axes that are driven by parallel kinematics. Altogether, four piezo actuators are driven differentially in the case of two-axis systems. They are arranged in pairs around 90° and both of them move the same platform at the same time (parallel kinematics), which is displaced around a fixed center of rotation. The basic setup of a three-axis, parallel-kinematic piezo tip/tilt system is illustrated in Fig. 3.

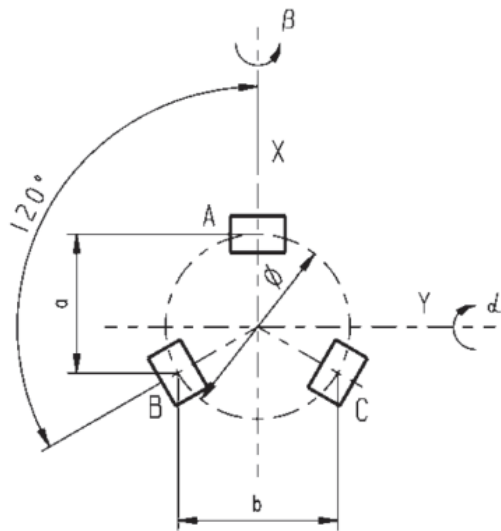

Fig. 3 Schematic diagram of parallel kinematics using the example of a three-axis piezo tip/tilt system – the tripod (image: PI)

The multi-axis design in "tripod" form is driven by three piezo actuators arranged with gaps of 120° in between. The advantage of driving with three independent piezo actuators means that, in addition to tilting, the platform is also capable of linear motion, which means for example, that the controller can make use of optical phase differences.

3 Condition on Delivery and Quality

Very high standards are set for the reliability and quality of all products from PI. The ISO certification, which not only focuses on a product but also customer expectations and satisfaction, was achieved back in 1994 and is recertified regularly.

The standard version of the piezo tip/tilt systems provides the best performance and at the same time, conservative system utilization. The system works reliably within the standard specifications and allows stable operation in the majority of customer-specific applications.

PI offers system tuning tailored specifically to the application for particular applications such as for example, extremely high dynamics or extremely stable positioning requirements. This makes it possible to optimize the servo control parameters specifically in order to achieve the best result for the respective application.

Of course, PI can also make customer-specific changes to the design of the standard product to match the exact customer's requirements on the installation space.

Each and every product is measured and qualified before dispatch. The system is subsequently supplied with the "Performance Test Protocol" as a further seal of quality – see Fig. 4.

Performance Test Protocol S-335.2SH - Linearity

File: 117034271_linearity_1_cal
 Protocol No.: FM 7.5-16 A4

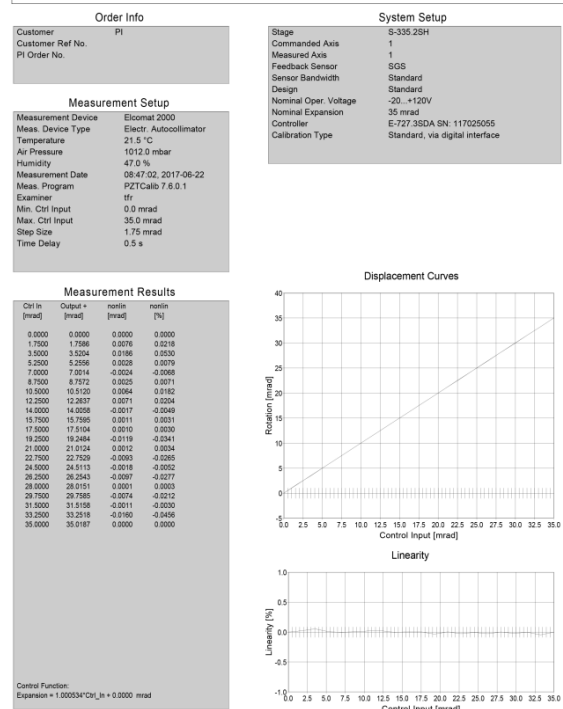

*Physik Instrumente (PI) GmbH & Co. KG, Auf der Römerstraße 1, 76228 Karlsruhe - Phone (+49) 721-4846-0, Fax (+49) 721-4846-100, e-mail info@pi.ws

Fig. 4 "Performance Test Protocol" of an S-335.2SH piezo tip/tilt mirror (image: PI)

4 Handling the Mirror



ATTENTION: Never remove the mirror by "levering" or applying mechanical force because forces can be transferred directly to the piezo actuators, which will react very sensitively. Chemical solvents should also not be used because they can easily penetrate the inside of the tip/tilt mirror and cause damage.

Excessive force increases the risk of damage to the seemingly robust piezo tip/tilt system particularly for mirror applications or when removing the mirror. The mirror should be mounted by the user according to the instructions in the user manual for the respective system.

A 3-point template is recommended for applying the adhesive. The template indicates the position the adhesive on the tip/tilt platform and restricts the quantity of the adhesive to be applied. This prevents applying too much adhesive, which could then penetrate the housing. In order to achieve the best possible adhesive bonding, an epoxy resin-based two-component adhesive should be chosen that has a hardening temperature of approx. 20 °C.

It is recommended to position the mirror on the platform with the help of a centering aid (Fig. 5). The template and the centering aid can be ordered at PI under the following link:

<https://www.physikinstrumente.com/en/products/accessories/adapter-plates-mounting-brackets/s-330xx-mirror-centering-aids-for-the-s-330-and-s-331-412418450/>

Alternatively, PI can also mount the mirror as part of the order.

If the mirror has to be removed, PI recommends heating the mirror carefully with a hot-air blow dryer to soften the adhesive. It should then be possible to remove the mirror easily.

If a larger mirror or a greater mass such as a beam splitter, is mounted on the system for dynamic applications, it may result in a decrease in performance or the characteristics could deviate from those specified by PI.

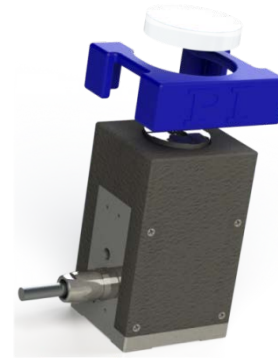

Fig. 5 S-335.2SH piezo tip/tilt systems with 3-D printed centering aid (blue) for applying a 1-inch mirror (image: PI)

The dynamic properties of the piezo tip/tilt system and therefore the respective servo control parameters in the controller react very sensitively to changes in the moment of inertia. Changes to the load and inertia conditions for those systems tuned specifically for the respective application by PI, will then not be able to fulfil the required specifications and would have to be tuned again for the new situation.

5 Controlling Tip/Tilt Systems

5.1 Choosing the Matching Control Electronics

PI offers analog and digital electronics for controlling the piezo tip/tilt systems. However, digital electronics (Fig. 6) are recommended for applications where demands on the system performance vary.



Fig. 6 E-727 digital controller (image: PI)

The servo control parameters can be adapted in the PIMikroMove software by simply pressing a button. The integrated ID chip in the piezo tip/tilt systems makes it possible to replace the controller or even the piezo tip/tilt system quickly and easily. The individual parameters of the piezo tip/tilt systems are read out of the controller automatically and the individual tuning data is then transferred.

In conjunction with the PIMikroMove software, the digital electronics offer a large range of functions and options for displaying the measured values for diagnostics and process control.

As a matter of course, PI also provides the entire measuring and control logic as Dynamic Link Library (DLL) for fast and easy integration into complex OEM and systems for the end customer. In addition, the LabVIEW integration provides an optional laboratory and prototype platform during the introductory phase.

The use of analog electronics is recommended for applications where the dynamic requirements are high and the necessary controller performance is less expensive. On top of that, it is planned to avoid time-consuming adaptation of the system properties in the future.

5.2 PIMikroMove: Easy Configuration and Startup

PIMikroMove is an integral part of the extensive software package that is included as standard in the scope of delivery of every digital PI controller. The software ensures easy and intuitive startup of the entire system.

Once the system has set up, the full range of functions is available to the user. In addition to easy position specification, selection of step size, and acceleration etc., it is also possible to implement macros for continuous motion sequences. So-called "controller macros" are available that can be used just as they are, or adapted accordingly.

"Host macros", which contain code for motion sequences, can be created in PIMikroMove. It is recommended to make use of the various high-level languages for complex trajectories. PIMikroMove supports several common high-level languages and graphical software such as C, C++, C#, Python, LabVIEW as well as MATLAB and Simulink.

System optimization and tuning are additional components of PIMikroMove. The P and I parts of the servo controller are available to the software to get the best possible performance from the system components. This means that the system can be optimized for the specific application.

In addition to tuning, PIMikroMove provides the option of analyzing the system for errors. Integrated software tools test each individual function of the system.

In this way, a graph of the current progression can be recorded during displacement. If there any changes in the current characteristic curve, it is possible to draw conclusions on the state of the system.

Note: To avoid damage, a sound knowledge of the system is necessary for tuning the piezo tip/tilt mirror. If required, PI will take care of tuning the piezo tip/tilt mirror according to the customer application.

6 During Operation

6.1 Hysteresis

In the case of open-loop systems, the displacement curves show strong hysteresis that results from ferroelectric polarization effects of the piezo ceramics. The "opening" of the voltage displacement curve reaches 10-15 % of the displacement angle – see Fig. 7.

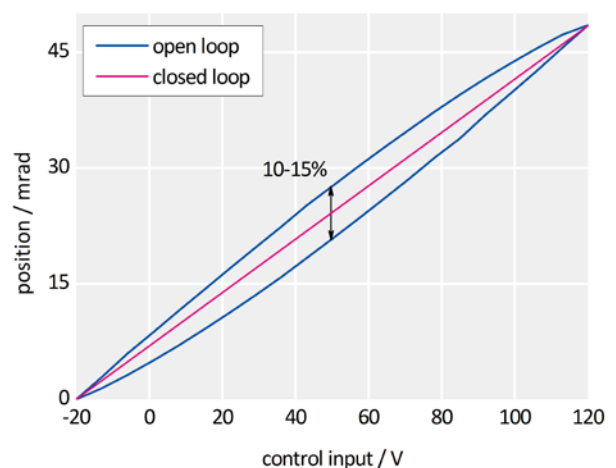

Fig. 7 Hysteresis of an S-335.2SH in a voltage range of -20 to 120 V (image: PI)

Position-controlled piezo tip/tilt systems from PI minimize this effect. That means that the systems achieve high absolute accuracy, linearity, and repeatability in the nanoradian and subnanoradian range.

6.2 Resonant Frequencies

One of the most important technical characteristics of high dynamics applications is the stiffness of the mechanical piezo tip/tilt system. The resonant frequency is derived as a function of the stiffness and serves to qualify the system. The general rule of thumb is: The higher the resonant frequency, the higher the maximum operating frequency that can be used for operating the system. Normally, the resonant frequency of positioning applications is considerably lower. In closed-loop operation, the maximum safe operating frequency is also limited by the phase and amplitude response of the system. The following also applies in this case: The higher the resonant frequency of the mechanics, the higher the control bandwidth can be set. The resonant frequency is directly dependent on the weights that are mounted on the piezo tip/tilt system. The dynamic performance is reduced by large weights to be moved.

Resonant frequency of an ideal spring-mass system:

$$f_0 = \left(\frac{1}{2\pi}\right) \sqrt{\frac{k_T}{m_{eff}}}$$

f_0 = resonant frequency [Hz]

k_T = spring stiffness [N/m]

m_{eff} = effective mass [kg]

The above equation shows that in order to double the resonant frequency of a spring-mass system, either the stiffness must be increased by a factor of 4 or the effective mass reduced by 25 % of its original value. In the case of extremely low resonant frequencies, it is only possible to realize quasistatic applications.

The system bandwidth can even limit the sensor bandwidth and servo controller performance (digital / analog electronics, filter and control type, bandwidth).

Piezo tip/tilt systems from PI are optimized for application-specific masses (for example, 1" mirror).

In Fig. 8, the first resonant frequencies are shown when using a ½-inch and a 1-inch mirror when compared to an unloaded system.

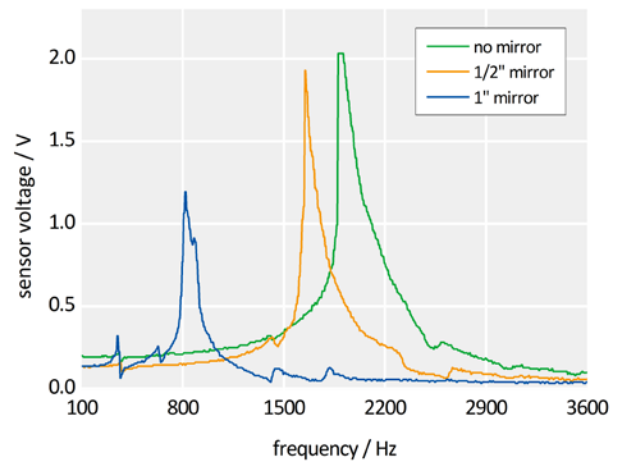

Fig. 8 Resonant frequencies of the S-335.2SH piezo tip/tilt system without load, ½-inch mirror and 1-inch mirror (image: PI)

6.3 Step Response and Settling Time

Fast response behavior is a characteristic feature of piezo actuators. A rapid change of the operating voltage causes a rapid change in the position of the piezo actuator and therefore a change in the tip/tilt platform's position.

If the control voltage increases suddenly, a piezo actuator can reach its nominal displacement in approx. 1/3 of the resonant frequency period, inasmuch as the voltage source is able to supply sufficient power. In this case, there is a strong overshoot of the target position.

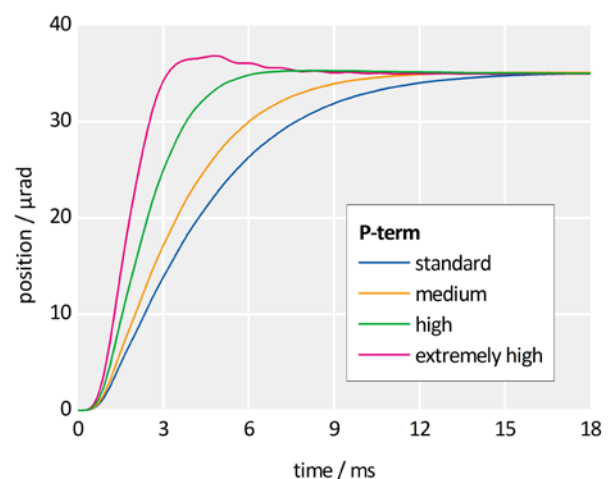

Fig. 9 Tuning an S-335.2SH piezo tip/tilt system for the fastest possible displacement. A 1" mirror is mounted (image: PI)

Fig. 9 shows several step responses of an S-335.2SH piezo system, based on the standard performance (as delivered, without tuning). The step response of the system can be influenced by tuning the servo controller.

Changing the load, for example, by changing the size of the mirror, also influences system performance. Fig. 10 shows how a change of mass influences a 50 % step (17:5 mrad, open loop) of a S-335-2SH piezo system.

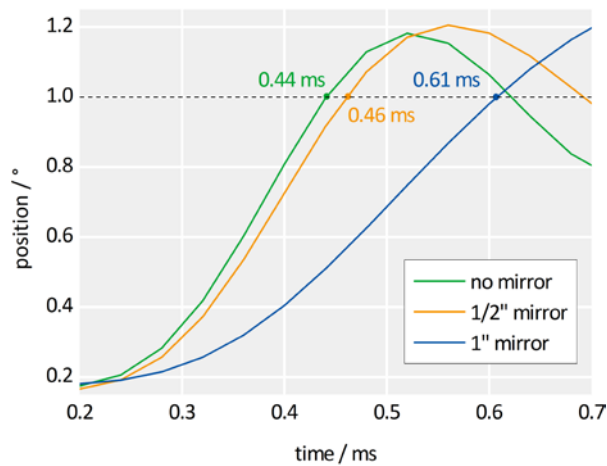

Fig. 10 Behavior of an S-335.2SH piezo tip/tilt system, open loop; without load, with 1/2-inch and 1-inch mirror (image: PI)

The positioning repeatability depends on the actual displacement of the piezo tip/tilt system and the type of sensor used. Basically, the repeatability is considerably higher for shorter than longer travel ranges.

Strain gauge sensors re installed into the most piezo tip/tilt systems. An SGS provides sufficient resolution and can be accommodated in the system to save space. BY evaluating the strain gauge sensors, which are attached directly to the piezo actuators, the actual position is continuously synchronized to the target position. Residual errors result from indirect position measuring and the strain gauge sensor technology itself. The piezo displacement makes it possible to determine the position of the platform.

On request, the repeatability of the system can be measure by PI. 100 measured points are recorded and the deviation between the target and actual position is acquired as "position error". The Fig. 11 (left-hand graphic) shows the measurement of an S-335.2SH piezo tip/tilt system. All deviations are compiled into a histogram shown on the right.

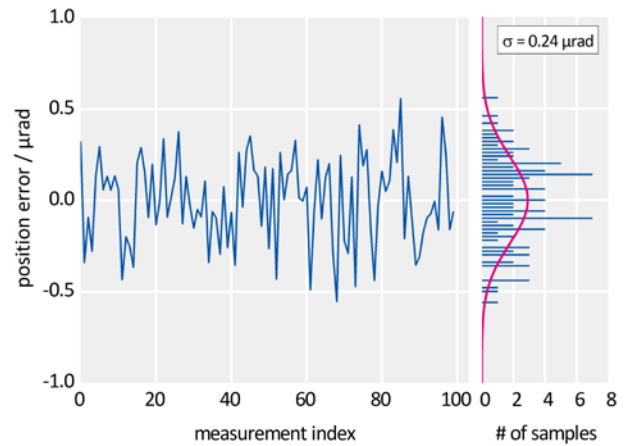

Fig. 11 Left-hand graph: Measurement of the repeatability of an S-335.2SH. Right-hand graph: Histogram with standard deviation (image: PI)

6.4 Heat Generation During Continuous Operation

! Note: Position-controlled piezo tip/tilt mirror have better temperature stability compared to open-loop systems. The highest accuracy is reached when the operating temperature and calibration temperature are identical. Piezo tip/tilt mirrors from PI are calibrated at 22 °C unless otherwise specified.

During long-term operation, it is possible that heat generation is limited by the operating frequency. Because piezo actuators behave like capacitive loads, their charge and discharge currents increase with the operating frequency. In addition to the operating frequency, thermal power loss in the tip/tilt mirror depends essentially on the voltage amplitude of the displacement, because this is squared in the power loss.

$$P \approx \frac{\pi}{4} \cdot \tan \delta \cdot f \cdot C \cdot U_{pp}^2$$

- P= power converted to heat [W]
- δ= dielectric loss factor
- f= operating frequency [Hz]
- C= actuator capacitance [F]
- U_{pp}= voltage (peak-peak) [V]

The thermal power loss of the piezo ceramics is approx. 8 to 12% of the electrical power input. Therefore, cooling may be necessary at higher frequencies and amplitudes.

The change in the temperature over time of an S-331.2SL piezo tip/tilt system at 100 V control voltage and 2000 Hz (sine) operating frequency is shown in Fig. 12. The change of temperature was measured at the ceramics.

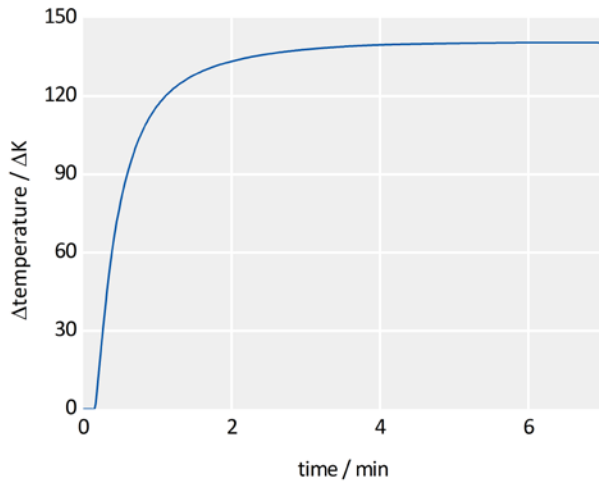

Fig. 12 Heating up of an S-331.2SL piezo tip/tilt system at a control voltage of 100 V and a frequency of 2000 Hz (image: PI)

6.5 Position Drift

Drift or creeping describes the change of displacement over time with unchanged control voltage.

The desired target position is controlled continuously in closed-loop system systems. The actual position is detected by strain gauge sensors and the difference between the target and actual value is minimized. Nevertheless, minimal position deviations can still occur when for example, fluctuations in the temperature of the surroundings cause expansion of the material in the overall system.

Drifting occurs more strongly in open-loop systems because the signals from the strain gauge sensors are not acquired. The actual and target positions are not compared. This means that the difference in measuring is not compensated and this results in drifting.

6.6 Lifetime

The lifetime of a piezo ceramic is not limited by wear and tear. Tests have shown that PICMA[®] piezo actuators that have undergone at least 100 billion cycles do not exhibit any measurable wear under appropriate ambient conditions and continue to operate according to specifications.

In PICMA[®] piezo actuators, the piezo ceramic is covered entirely by a ceramic insulation layer that protects the actuators from humidity and failure resulting from increased leakage current. The monolithic piezoceramic block of a PICMA[®] actuator is very reliable even under extreme ambient conditions and this extends the lifetime considerably

Slots on the sides of PICMA[®] actuators effectively prevent an excessive increase of mechanical tensile stress in the passive regions of the stack as well uncontrolled cracking that would lead to electrical breakdowns and therefore damage to the actuator.

The meander-shaped design of the external contact strips ensures stable electrical contact to all inner electrodes, even under extreme dynamic loads (Fig. 13).



Fig. 13 PICMA[®] actuators with patented outer electrodes for up to 20 A charging current (image: PI)

There is no general formula for calculating the lifetime of piezo ceramics because many of the parameters such as for example, temperature, humidity, voltage, acceleration, push and pull forces, preload, operating frequency, and insulating material exert a nonlinear influence.

PI piezo ceramics are not only optimized for maximum displacement, but also for long lifetime under practical operating conditions.

7 OEM Engineering and Solutions

Joint development of solutions unites. This is the intention of members of the customer service staff at PI. This starts with the preliminary informative discussion and extends far beyond delivery.

Because a large part of the OEM business is based on customer-specific products, the developer's know-how and longstanding experience is an important requirement for success.

Extensive testing and production equipment allow PI to react quickly to the development and production requirements of highly complex custom products and assemblies. All development procedures and production processes, from the idea to the final product, are controlled via a comprehensive management system.

All systems manufactured by PI undergo endurance testing, where various types of load, operating and control conditions were taken into consideration.

8 FEM Optimization

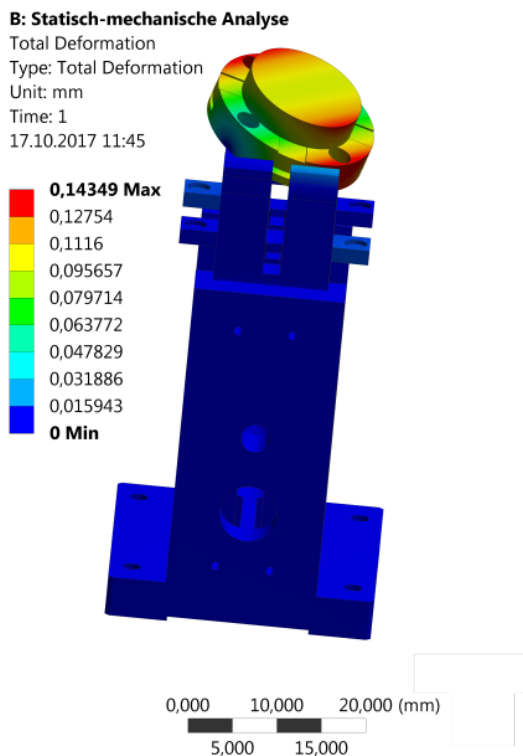

Fig. 14 FEM simulation of platform tilting at a specified control voltage using the example of the S-335.2SH (image: PI)

Development engineers at PI use the latest FEM (Finite Elements Method) analytical tools as well as CAD software for simulating and developing new mechanical systems. This ensures the functionality, precision, and performance before a prototype is set up.

For example, flexures, which serve as guide for the platform, are optimized in this way during development of the piezo tip/tilt systems. FEM optimization maximizes the stiffness perpendicular to the direction of motion and therefore reduces undesired creeping.

Modal analysis during FEM optimization helps to reveal later resonant frequencies and other dynamic system characteristics. Fig. 14 shows the result of an FEM simulation of platform displacement of an S-335.2SH piezo tip/tilt system at a control voltage of 100 V.

9 Simulation of the Overall System

The resonant frequencies revealed by the modal analysis represent one of the parameters for a holistic simulation model. In addition, the electrical capacities of piezo ceramics, servo control parameters, and system damping are relevant as input data for simulating the overall system.

Therefore, the simulation model represents a step towards the digital twin of the tip/tilt mirror in conjunction with the electronics unit that in turn, provides a virtual representation of the performance of the real product. Feasibility analyses of customer requirements and an early and sound risk analysis for the product can be done very quickly. Development engineers at PI use the latest FEM (Finite Element Method) analytical tools as well as CAD software for simulating and developing new mechanical systems. This ensures the functionality, precision, and performance before a prototype is set up.

10 Author

Armin Karle is development engineer in the development department for piezo systems at Physik Instrumente (PI) GmbH & Co. KG in Karlsruhe, Germany.

About PI

Well known for the high quality of its products, PI (Physik Instrumente) has been one of the leading players in the global market for precision positioning technology for many years. PI has been developing and manufacturing standard and OEM products with piezo or motor drives for more than 40 years.

Continuous development of innovative drive concepts, products, and system solutions and more than 200 technology patents distinguish the company history today.

PI develops, manufactures, and qualifies all core technology itself: From piezo components, -actuators, and motors as well as magnetic direct drives through air bearings, magnetic and flexure guides to nanometrological sensors, control technology, and software. PI is therefore not dependent on components available on the market to offer its customers the most advanced solutions. The high vertical range of manufacturing allows complete control over processes and this allows flexible reaction to market developments and new requirements.

By acquiring the majority shares in ACS Motion Control, a worldwide leading developer and manufacturer of modular motion controllers for multi-axis drive systems, PI can also supply customized complete systems for industrial applications that make the highest demand on precision and dynamics. In addition to four locations in Germany, the PI Group is represented internationally by fifteen sales and service subsidiaries.